

CSS series

Connection with dual spring terminal per pole

Series **CSS** is the “two spring clamp terminal per contact” counterpart of series **CSH** connectors, which have one spring-clamp terminal per contact.

 CSS connection technology see page 23

In series **CSS** inserts **are made available to the user with two spring clamp terminals per contact** so that two conductors can be connected to each of them.

Series **CSS** inserts share the mating interface (dimensions) with equally sized inserts of series **CNE** (screw-type) **CCE** (crimp type) **CSH** (spring-type with actuator button SQUICH®), **CT** (screw-type with 45° terminal block) and **CTSE** (spring-type with 45° terminal block).

With connectors like **CSS** and suitably developed housings, electric motors can be prepared for the fastest and safest installation. The motor terminal box may be replaced by the specially developed motor connection angled housing **CVI 10 LA** or **MVI 10 LAP32** (see page 450). The “57.27” size for the connector insert and the housing has been chosen to fulfil motor connection requirements.

Star or delta (triangle) bridges may be realized in the mating (free) female connector, realizing simple bridges thanks to the double terminals per pole feature of **CSS**, by short conductors stripped at both ends and “U-bent”. Fast and easy exchange of a motor for maintenance is made easy, reducing costs for downtime.

* DESINA standards for **DE**centralized and **St**andardized **IN**stall**A**ction Technology. This working group was founded by the Association of German Machine Tools Manufacturers (VDW) with the target to develop a field bus independent, standardized installation system for machines and production plants. The task was fulfilled in close cooperation with machine tools manufacturers, the automotive industry and their supply chain. **DESINA** specifications have been transferred to series **ISO 22570** international standards.

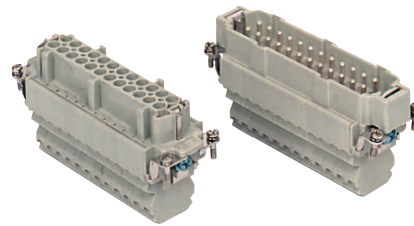

SUM-UP

- Two spring clamp terminals per contact**
- No special tools are needed**
- Suitable for standard hoods/housings size “44.27”, “57.27”, “77.27”, “77.62”, “104.27”, “104.62” high construction version**
- Vibration and shock resistant**
- Ideal as motor connectors, as they provide the possibility to connect motor windings in star and delta configuration**
- The 10 pole version is specified by **DESINA** Specifications* and by ISO 22570-1:2009 as type 1 connector for motor connection (6 poles for three-phase star or delta connection + 2 poles for breaking circuit + 2 poles for temperature sensing motor protection circuit)**
- Built-in silver plated contacts**

CSS series

TECHNICAL FEATURES

Insert series		CSS
No. of poles ¹⁾	Main contacts + ⊕	6, 10, 16, 24, (32 = 2x16), (48 = 2x24)
	auxiliary contacts	—
Rated current ²⁾		16A
EN IEC 61984 Pollution degree 3	rated voltage	500V
	rated impulse voltage	6kV
	pollution degree	3
EN IEC 61984 Pollution degree 2	rated voltage	400/690V
	rated impulse voltage	6kV
	pollution degree	2
UL / CSA certification	rated voltage (a.c./d.c.)	600V
Contact resistance		≤ 3 mΩ
Insulation resistance		≥ 10 GΩ
Ambient temperature limit (°C)	min	-40 °C
	max	+125 °C
Degree of protection	with enclosures	IP65, IP66/IP69, IP66/IP67/IP69, IP66/IP68/IP69 (according to type and model)
	without enclosures (in mated condition) - termination side on male and female inserts - mating side on female inserts	IP20 (IPXXB)
Conductor connections		spring type
Conductor cross-sectional area	mm ²	0,14 - 2,5
	AWG	26 - 14
Mechanical endurance (mating cycles)		≥ 500

1) Polarities shown in brackets may be obtained by using two inserts in their own double-sized housings

2) Please check the inserts derating diagrams to establish the actual maximum operating current according to the ambient temperature, the conductor cross-sectional area, the polarity of the connector, and any external constraint may derive e.g. by the continuous operating temperature sustained by the chosen conductor sheathing or by end-product safety standards fixing max allowed temperature rise on terminals (e.g. 30 K, 45 K or 50 K)

CSS 6 poles + ⊕ 16A - 500V

enclosures: size "44.27"	page:
C-TYPE IP65 or IP66/IP69	387 - 392
C7 IP67, single lever	436 - 437
V-TYPE IP65 or IP66/IP69, single lever	444 - 447
BIG hoods	466 - 467
T-TYPE IP65 insulating	480 - 481
T-TYPE / W IP66/IP69 insulating	489
HYGIENIC T-TYPE / H IP66/IP69	501
HYGIENIC T-TYPE / C IP66/IP69, -50 °C	506
W-TYPE for aggressive environments	521
E-Xtreme® corrosion proof	530 - 531, 542, 550 - 551
EMC	578
Central lever	603 - 605
LS-TYPE	618 - 619
IP68	632 - 635
panel supports:	page:
COB	652 - 653

inserts,
connection with dual spring
terminal per pole

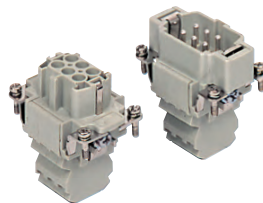

can be mated with CNE, CCE, CTSE, CSH inserts

description	part No.
-------------	----------

dual spring terminal per pole
female inserts with female contacts
male inserts with male contacts

CSSF 06
CSSM 06

The CSS series inserts can be inserted in flush mounted enclosures or in fixed / portable high enclosures.

- characteristics according to EN 61984:

16A 500V 6kV 3
16A 400/690V 6kV 2

- certified

- rated voltage according to UL/CSA: 600V
- insulation resistance: ≥ 10 GΩ
- ambient temperature limit: -40 °C ... +125 °C
- made of self-extinguishing thermoplastic resin UL 94V-0
- mechanical life: ≥ 500 cycles
- contact resistance: ≤ 3 mΩ
- for max. current load see the connector inserts derating diagram below; for more information see page 28

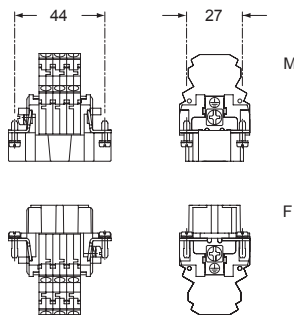

contacts side (front view)

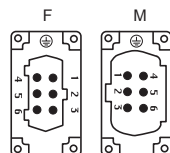

- inserts with plate for section conductors: 0,14 - 2,5 mm² - AWG 26 - 14
- conductors stripping length: 9...11 mm

Connection technology

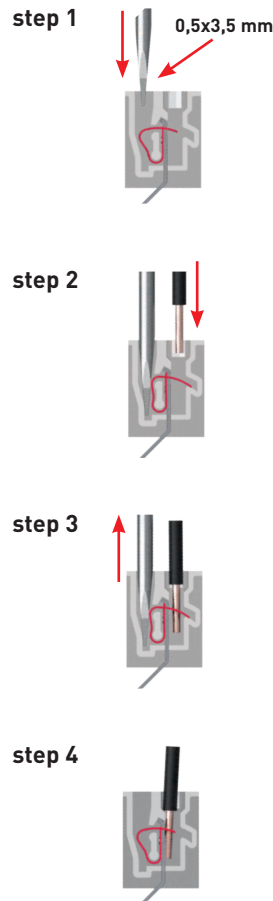

CSS 06 poles connector inserts
Maximum current load derating diagram

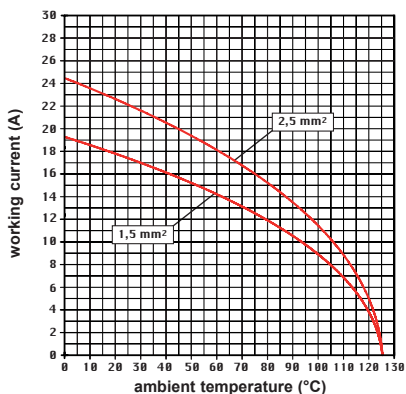

CSS 10 poles + ⊕ 16A - 500V

enclosures: size "57.27"	page:
C-TYPE IP65 or IP66/IP69	393 - 401
C7 IP67, two levers	438
V-TYPE IP65 or IP66/IP69, single lever	448 - 453
BIG hoods	468 - 469
T-TYPE IP65 insulating	482 - 483
T-TYPE / W IP66/IP69 insulating	490
HYGIENIC T-TYPE / H IP66/IP69	502
HYGIENIC T-TYPE / C IP66/IP69, -50 °C	507
W-TYPE for aggressive environments	522
E-Xtreme® corrosion proof	532 - 533, 543, 552 - 553
EMC	579
Central lever	606 - 608
LS-TYPE	620 - 621
IP68	636 - 639
panel supports: COB	page: 652 - 653

inserts,
connection with dual spring
terminal per pole

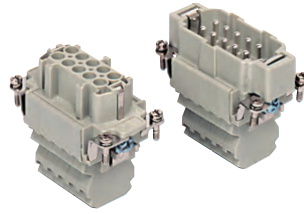

can be mated with CNE, CCE, CTSE, CSH inserts

description	part No.
-------------	----------

dual spring terminal per pole
female inserts with female contacts
male inserts with male contacts

CSSF 10
CSSM 10

The CSS series inserts can be inserted in flush mounted enclosures or in fixed / portable high enclosures.

- characteristics according to EN 61984:

16A 500V 6kV 3
16A 400/690V 6kV 2

- certified

- rated voltage according to UL/CSA: 600V
- insulation resistance: $\geq 10 \text{ G}\Omega$
- ambient temperature limit: $-40 \text{ }^\circ\text{C} \dots +125 \text{ }^\circ\text{C}$
- made of self-extinguishing thermoplastic resin UL 94V-0
- mechanical life: ≥ 500 cycles
- contact resistance: $\leq 3 \text{ m}\Omega$
- for max. current load see the connector inserts derating diagram below; for more information see page 28

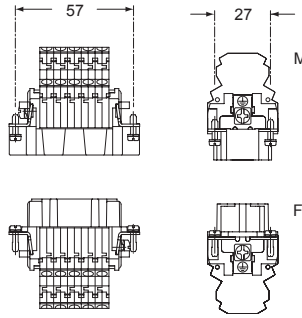

contacts side (front view)

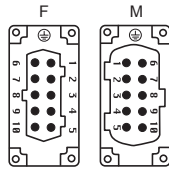

- inserts with plate for section conductors: 0,14 - 2,5 mm² - AWG 26 - 14
- conductors stripping length: 9...11 mm

CSS 10 poles connector inserts
Maximum current load derating diagram

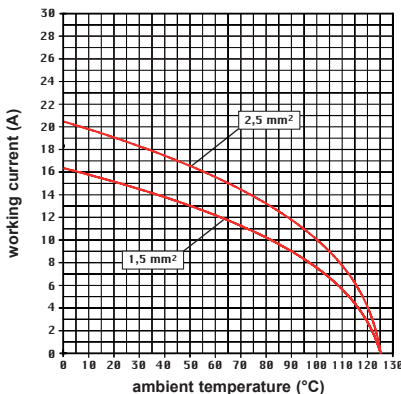

Connection technology

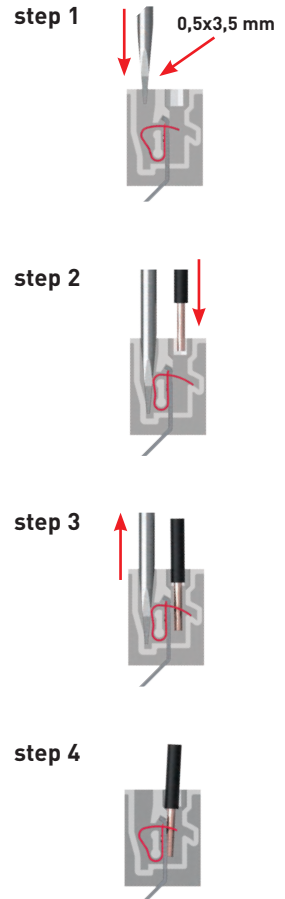

CSS 16 poles + ⊕ 16A - 500V

enclosures: size "77.27"	page:
C-TYPE IP65 or IP66/IP69	402 - 411
C7 IP67, two levers	439 - 440
V-TYPE IP65 or IP66/IP69, single lever	454 - 458
BIG hoods	470 - 471
T-TYPE IP65 insulating	484 - 485
T-TYPE / W IP66/IP69 insulating	491
HYGIENIC T-TYPE / H IP66/IP69	503
HYGIENIC T-TYPE / C IP66/IP69, -50 °C	508
W-TYPE for aggressive environments	523
E-Xtreme® corrosion proof	534 - 535, 544, 554 - 555
EMC	580
Central lever	609 - 611
LS-TYPE	622 - 623
IP68	640 - 643
panel supports:	page:
COB	652 - 653

inserts,
connection with dual spring
terminal per pole

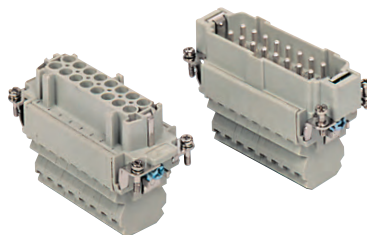

can be mated with CNE, CCE, CTSE, CSH inserts

description

part No.

- dual spring terminal per pole
- female inserts with female contacts
- male inserts with male contacts

CSSF 16
CSSM 16

The CSS series inserts can be inserted in flush mounted enclosures or in fixed / portable high enclosures.

- characteristics according to EN 61984:

16A 500V 6kV 3
16A 400/690V 6kV 2

- certified

- rated voltage according to UL/CSA: 600V
- insulation resistance: $\geq 10 \text{ G}\Omega$
- ambient temperature limit: $-40 \text{ }^\circ\text{C} \dots +125 \text{ }^\circ\text{C}$
- made of self-extinguishing thermoplastic resin UL 94V-0
- mechanical life: ≥ 500 cycles
- contact resistance: $\leq 3 \text{ m}\Omega$
- for max. current load see the connector inserts derating diagram below; for more information see page 28

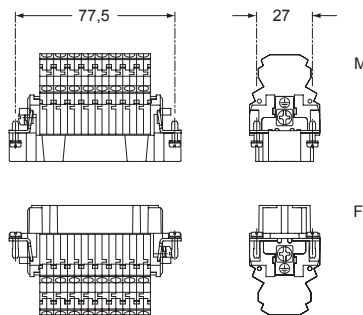

contacts side (front view)

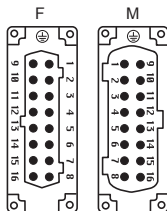

- inserts with plate for section conductors: 0,14 - 2,5 mm² - AWG 26 - 14
- conductors stripping length: 9...11 mm

Connection technology

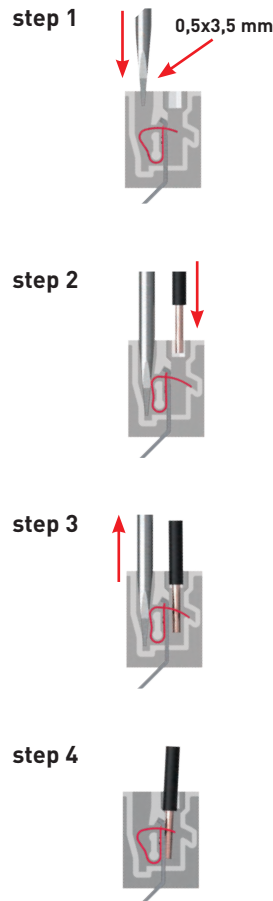

CSS 16 poles connector inserts
Maximum current load derating diagram

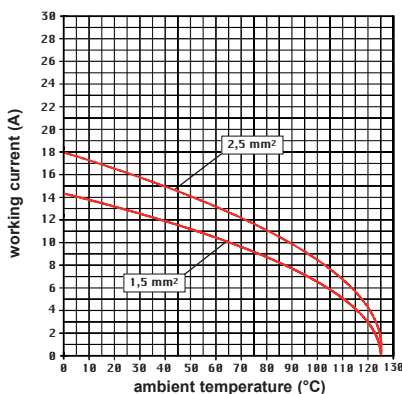

CSS 24 poles + ⊕ 16A - 500V

enclosures: size "104.27"	page:
C-TYPE IP65 or IP66/IP69	412 - 423
C7 IP67, two levers	441 - 442
V-TYPE IP65 or IP66/IP69, single lever	459 - 463
BIG hoods	472 - 473
T-TYPE IP65 insulating	486 - 487
T-TYPE / W IP66/IP69 insulating	492
HYGIENIC T-TYPE / H IP66/IP69	504
HYGIENIC T-TYPE / C IP66/IP69, -50 °C	509
W-TYPE for aggressive environments	524
E-Xtreme® corrosion proof	536 - 537, 545, 556 - 557
EMC	581
Central lever	612 - 614
LS-TYPE	624 - 625
IP68	644 - 647
panel supports: COB	page: 652 - 653

inserts,
connection with dual spring
terminal per pole

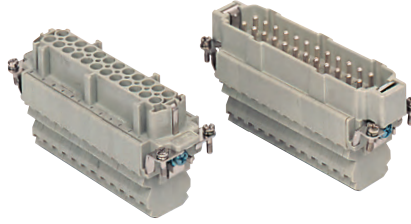

can be mated with CNE, CCE, CTSE, CSH inserts

description	part No.
-------------	----------

dual spring terminal per pole
female inserts with female contacts
male inserts with male contacts

CSSF 24
CSSM 24

The CSS series inserts can be inserted in flush mounted enclosures or in fixed / portable high enclosures.

- characteristics according to EN 61984:

16A 500V 6kV 3
16A 400/690V 6kV 2

- certified

- rated voltage according to UL/CSA: 600V
- insulation resistance: $\geq 10 \text{ G}\Omega$
- ambient temperature limit: $-40 \text{ }^\circ\text{C} \dots +125 \text{ }^\circ\text{C}$
- made of self-extinguishing thermoplastic resin UL 94V-0
- mechanical life: ≥ 500 cycles
- contact resistance: $\leq 3 \text{ m}\Omega$
- for max. current load see the connector inserts derating diagram below; for more information see page 28

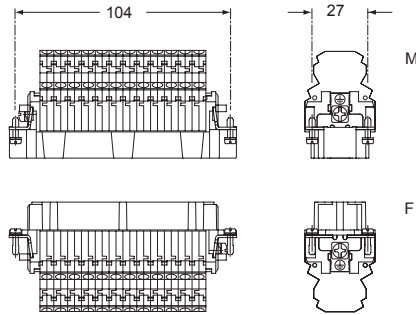

contacts side (front view)

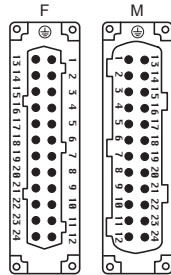

- inserts with plate for section conductors: 0,14 - 2,5 mm² - AWG 26 - 14
- conductors stripping length: 9...11 mm

CSS 24 poles connector inserts
Maximum current load derating diagram

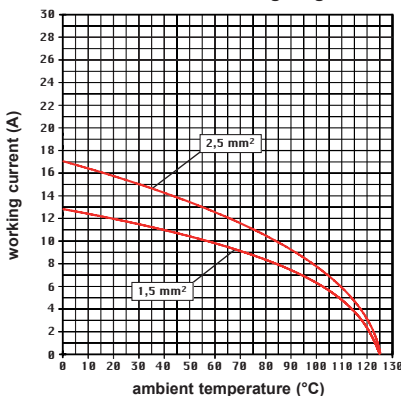

Connection technology

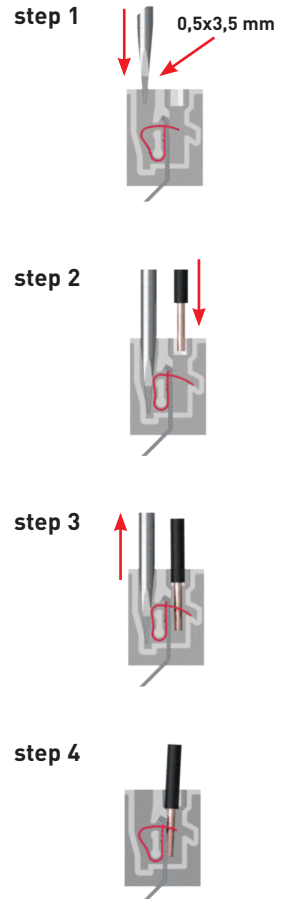

CSS 32 poles + ⊕ 16A - 500V

enclosures:
size "77.62"

page:

C-TYPE IP65 or IP66/IP69
W-TYPE for aggressive environments
E-Xtreme® corrosion proof

424 - 429
525
546

inserts,
connection with dual spring
terminal per pole

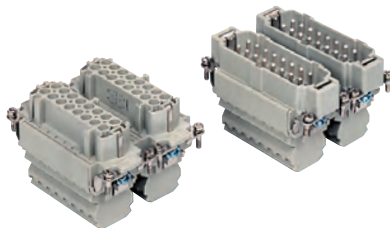

can be mated with CNE, CCE, CTSE, CSH inserts

description

part No.

part No.

dual spring terminal per pole
female inserts with female contacts, No. (1-16) and (17-32)
male inserts with male contacts, No. (1-16) and (17-32)

CSSF 16
CSSM 16

CSSF 16 N
CSSM 16 N

The CSS series inserts can be inserted in flush mounted enclosures or in fixed / portable high enclosures.

- characteristics according to EN 61984:

16A 500V 6kV 3

16A 400/690V 6kV 2

- certified

- rated voltage according to UL/CSA: 600V

- insulation resistance: $\geq 10 \text{ G}\Omega$

- ambient temperature limit: $-40 \text{ }^\circ\text{C} \dots +125 \text{ }^\circ\text{C}$

- made of self-extinguishing thermoplastic resin UL 94V-0

- mechanical life: ≥ 500 cycles

- contact resistance: $\leq 3 \text{ m}\Omega$

- for max. current load see the connector inserts derating diagram below; for more information see page 28

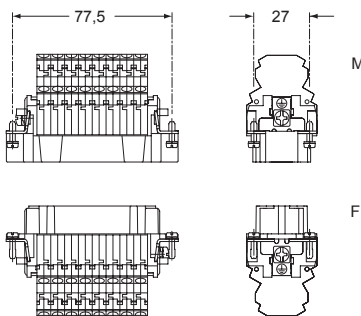

contacts side (front view)

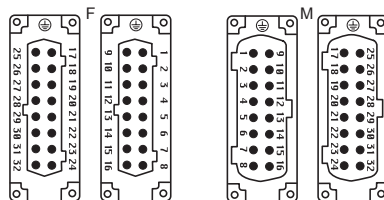

- inserts with plate for section conductors:
0,14 - 2,5 mm² - AWG 26 - 14
- conductors stripping length: 9...11 mm

Connection technology

step 1

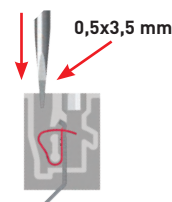

step 2



step 3



step 4



CSS 32 poles connector inserts
Maximum current load derating diagram

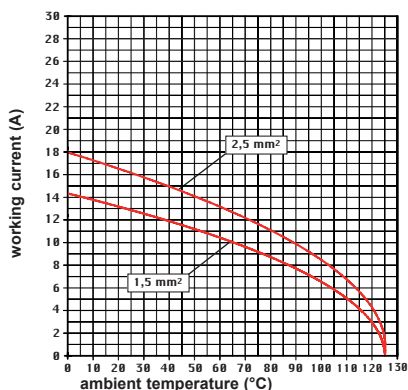

CSS 48 poles + ⊕ 16A - 500V

enclosures:
size "104.62"

page:

C-TYPE IP65 or IP66/IP69
W-TYPE for aggressive environments
E-Xtreme® corrosion proof

430
526
547

inserts,
connection with dual spring
terminal per pole

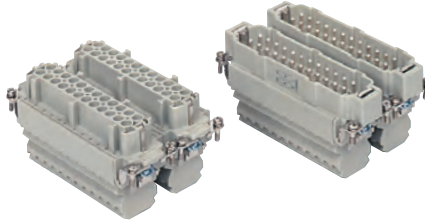

can be mated with CNE, CCE, CTSE, CSH inserts

description	part No.	part No.
-------------	----------	----------

spring terminals with actuator button
female inserts with female contacts, No. (1-24) and (25-48)
male inserts with male contacts, No. (1-24) and (25-48)

CSSF 24
CSSM 24

CSSF 24 N
CSSM 24 N

The CSS series inserts can be inserted in flush mounted enclosures or in fixed / portable high enclosures.

- characteristics according to EN 61984:

16A 500V 6kV 3
16A 400/690V 6kV 2

- certified

- rated voltage according to UL/CSA: 600V
- insulation resistance: $\geq 10 \text{ G}\Omega$
- ambient temperature limit: $-40 \text{ }^\circ\text{C} \dots +125 \text{ }^\circ\text{C}$
- made of self-extinguishing thermoplastic resin UL 94V-0
- mechanical life: ≥ 500 cycles
- contact resistance: $\leq 3 \text{ m}\Omega$
- for max. current load see the connector inserts derating diagram below; for more information see page 28

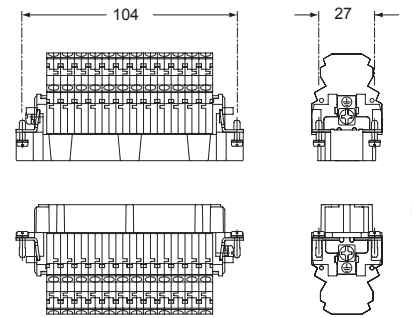

contacts side (front view)

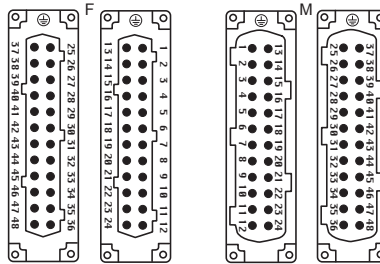

- inserts with plate for section conductors: 0,14 - 2,5 mm² - AWG 26 - 14
- conductors stripping length: 9...11 mm

CSS 48 poles connector inserts
Maximum current load derating diagram

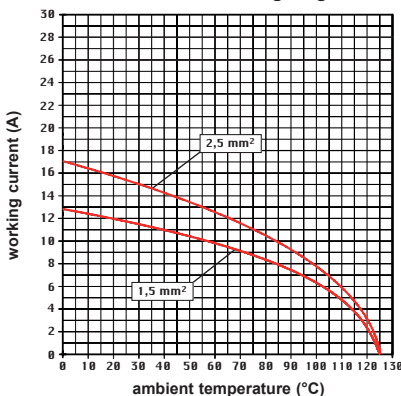

Connection technology

