

# ARCTIC GAS DENSITY MONITOR

Swiss based Trafag offers precise, reliable and maintenance-free instruments developed for density monitoring of SF<sub>6</sub> and related alternative gases. Monitoring is based on the gas density reference principle. The arctic monitor is based on the gas density reference principle and reliably keeps the liquefaction alarm status until it returns to normal condition. Thus offering the most reliable solution on the market by directly monitoring the insulating gas density.



## Applications

- High voltage technology
- Medium voltage technology
- SF<sub>6</sub> and variety of alternative mixed gases

## Features

- Exact switching output at all temperatures
- For arctic temperatures down to: -60°C
- Independent, galvanically separated switching circuits
- Accurate and reliable under extreme conditions
- Process gas liquefaction alarm

## Technical Data

Measuring principle	Absolute pressure reference gas measuring system	Quantity of switchpoints	1 ... 4 microswitches
Measuring range	0 ... 1100 kPa abs. @ 20°C	Dial	Scale and units selectable
Output signal	Floating change-over contact (SPDT)	Ambient temperature	-60°C ... +80°C

01/2021

Data sheet H72513g

Subject to change

## Ordering information/type code

		87x8	XXXX	XX	XXXX	XX	XX	XX
<b>Custom build code</b>	<b>Arctic gas density monitor with microswitches</b>							
	One microswitch		8718					
	Two microswitches		8728					
	Three microswitches		8738					
	Four microswitches		8748					
<b>Monitor wire terminal block</b>	Standard wire terminal			20				
<b>Pressure connection</b>	Threaded, axial and radial types				1XXX			
	Flanged and cap nut, axial and radial types				2XXX			
	Compartment immersion types				5XXX			
<b>Code number</b>	Determined by Trafag						XX	
<b>Options</b>	Basic density indicator dial with two colour sectors without markings							60
	Density indicator dial with scale according to customer specification							61
	Low pressure indicator							66
	Process gas wetted O-rings composed of IIR							C2
	Microswitch outlet							
	EMC-cable gland M20x1.5, brass nickel-plated, for cable-ø 7 ... 12.5 [mm]							10
	EMC-cable gland M20x1.5, brass nickel-plated, for cable-ø 8 ... 11 [mm]							07
	EMC-cable gland M20x1.5, brass nickel-plated, for cable-ø 11 ... 14 [mm]							08
	EMC-cable gland M25x1.5, brass nickel-plated, for cable-ø 8 ... 16 [mm]							11
	EMC-cable gland M25x1.5, brass nickel-plated, for cable-ø 12.5 ... 20.5 [mm]							17
	ITT Cannon connector							12
	Blank plug M20x1.5, brass nickel-plated <sup>1)</sup>							13
	Blank plug M25x1.5, brass nickel-plated <sup>1)</sup>							04
	Blank plug M25x1.5, PA <sup>1) 2)</sup>							05
	Process gas damping element <sup>3)</sup>							49
	Integrated test valve for DILO DN8 test port coupling with M26x1.5 protective cap							
	Standard test port orientation							W3
	Test port orientation 180°							W0
	Test port orientation 270°							W1
	Test port orientation 90°							W2
	Integrated re-filling valve for DILO DN8 filling port coupling with M26x1.5 protective cap							
	Standard filling port orientation							F3
	Filling port orientation 180°							F0
Filling port orientation 270°							F1	
Filling port orientation 90°							F2	
<b>Accessories</b>	Thermal insulation for probe housing							06
	Thermal foam cover with drain holes							37
	Weather protection cover							46
	Pressure connection adapter 2300 - G1/2" male							N1

<sup>1)</sup> Requires single-cable connection by microswitch outlet

<sup>2)</sup> Select if EMC-cable gland is procured locally

<sup>3)</sup> Without IP compatibility, not for use in operation

## Further customised parameterisation to be indicated

Process gas	SF <sub>6</sub> , SF <sub>6</sub> mixed gas, customer specific alternative gas
Variety of units for density dial	kPa, bar, MPa, psi (abs., rel.), kg/m <sup>2</sup> , kg/cm <sup>2</sup> , also dual units available
Switchpoint @ 20°C <sup>1)</sup>	Microswitch 1 p= xxx
	Microswitch 2 p= xxx
	Microswitch 3 p= xxx
	Microswitch 4 p= xxx

## Specifications

<b>Mechanical density monitoring</b>	Monitoring principle <sup>2)</sup>	Absolute pressure reference gas measuring system
	Monitoring range	0 ... 1100 kPa abs. @ 20°C
	Monitoring output	Floating change-over contact (SPDT)
	Quantity of switchpoints	1 ... 4 microswitches
	Monitoring accuracy	Refer to density indicator and microswitch sections
<b>Environmental conditions</b>	Ambient temperature	-60°C ... +80°C
	Protection	IP65 and IP67
	Humidity	IEC 60068-2-30 (damp heat, cyclic, 100 % RH @ +55°C), membrane provides condensation compensation
	Overpressure	1300 kPa abs.
	Shock	70 g / 3 ms / 10'000 times at all axes excited on process connection without damage to instrument
	Routine inspection of gas tightness	Integral pressure testing with 6 bar rel. helium SF <sub>6</sub> leakage rate less than 1·10 <sup>-8</sup> mbar · l/s
<b>Mechanical data</b>	Process gas wetted material	Process connection and measuring system: 1.4404, 1.4435, 1.4571 (AISI316L, AISI316Ti) Test and re-filling valve: 1.4404 (AISI316L), CuZn39Pb3 (C38500) Sealing: EPDM <sup>3)</sup> , IIR as option <sup>4)</sup>
	Housing	AISI10Mg, powder coated
	Screwed cable gland	Brass nickel plated, PA as option
	Dial	Dial face and pointer: Aluminium sheet Window: PMMA
	Weight	Gas density monitor: ~ 800 ... 1000g Gas density monitor with integrated test or re-filling valve ~ 1100 ... 1300g

<sup>1)</sup> Factory setting for decreasing or increasing pressure available

<sup>2)</sup> Depending on process gas requirements, the fully sealed reference gas chamber contains up to 0.001kg of SF<sub>6</sub>. The relevant national regulations governing the disposal of hazardous waste apply and must be followed.

Decommissioned or defective monitors can be returned to the manufacturer for disposal in a safe and environmentally appropriate manner.

<sup>3)</sup> SF<sub>6</sub> qualified

<sup>4)</sup> IIR is limited to temperature range of -40°C ... +80°C

Density indicator		
	Main dial	Low pressure indication option
Indicator principle	Absolute pressure, fully temperature compensated by means of sealed reference gas chamber	Indication of relative pressure. For safety reasons it is not temperature compensated
Scale	Colour sectors (standard red/yellow/green or red/green), switchpoint markings, single or dual units	Single unit, graduated range
Unit	Optional kPa, MPa, bar, psi (abs., rel., a, g), kg/m <sup>2</sup> , kg/cm <sup>2</sup> , customer specific units available	According to main dial unit
Numbered range	up to 180 kPa @ 20°C between lowest and highest indicated value <sup>1)</sup>	Vacuum up to lowest switchpoint, 500 kPa rel. max.
Accuracy within numbered range	± 10 kPa @ 20°C	Up to 200 kPa rel.: ± 20 kPa up to 500 kPa rel.: ± 10% MV

<sup>1)</sup> Typically ranges are from lock-out switchpoint to filling pressure (no high-alarm), or from lock-out switchpoint to high-alarm switchpoint

### Gas density monitor with main dial and low pressure indicator in standard orientation (electrical connection in 6 o'clock position)

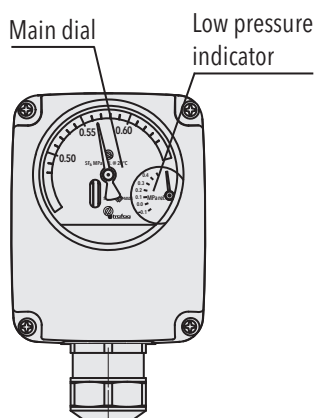

### Density indicator dial according to customer specification Availability of a full variety of units including dual range indication This also includes dial rotated by 90°/180°/270°

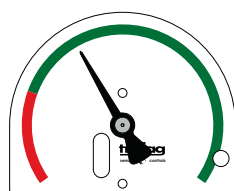

87x8.XX.XXXX.XX.60.XX.XX

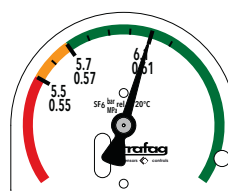

87x8.XX.XXXX.XX.60.61XX

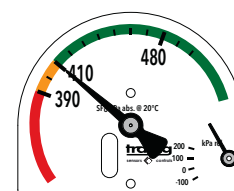

87x8.XX.XXXX.XX.60.61.66.XX

### Gas density monitor without indication

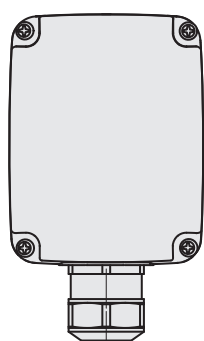

87x8.XX.XXXX.XX.XX.XX

### Customised dial orientation based on electrical connection position

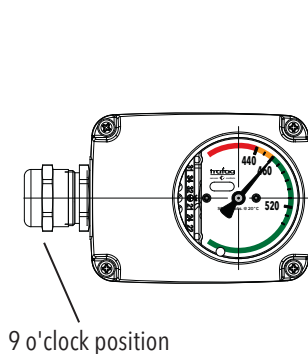

9 o'clock position

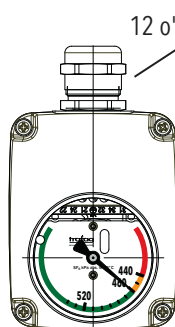

12 o'clock position

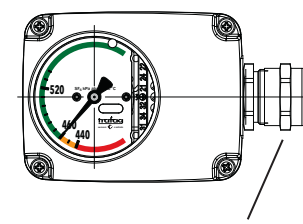

3 o'clock position

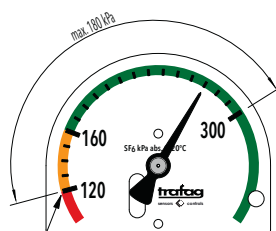

Lowest switchpoint setting: 120 kPa abs. @ 20°C  
Distance from lowest to highest switchpoint: up to 180 kPa @ 20°C

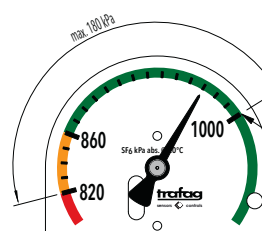

Highest switchpoint setting: 1000 kPa abs. @ 20°C  
Distance from lowest to highest switchpoint: up to 180 kPa @ 20°C

Microswitch and switchpoint		
<b>Microswitch</b>	Output signal	Floating change-over contact (SPDT)
	Resistive load (inductive load) rating	AC - 250 V 10 (1.5) A DC - 250 V 0.1 (0.05) A, 220 V 0.25 (0.2) A, 110 V 0.5 (0.3) A, 24 V 2 (1) A
	Resistance of insulation	>100 MΩ, 500 VDC, ex factory
	Dielectrical strength	2 kVAC, 50Hz, terminal to ground (earth)
	Switching cycle capacity	Up to 1 Mio. mechanical, more than 10'000 with maximum load
	Effect of vibration	4 g / 20...100 Hz effects no contact bounce at 5 kPa minimum distance from set switchpoint
<b>Switchpoint setting</b>	Factory adjustment	According to customer specification Standard setting is for decreasing pressure
	Lowest switchpoint setting	120 kPa abs. @ 20°C
	Highest switchpoint setting	1000 kPa abs. @ 20°C
	Distance from the lowest to the highest switchpoint <sup>1)</sup>	Up to 180 kPa @ 20°C
	Switching differential	3 ... 7 kPa typ. (15 kPa max.) if lowest to highest switchpoint distance is up to 130 kPa 5 ... 10 kPa typ. (20 kPa max.) if lowest to highest switchpoint distance is 130 ... 180 kPa

<sup>1)</sup> Distance from lock-out to high-alarm pressure, or from lock-out to filling pressure (no high-alarm)

Switchpoint accuracy					
		+20°C	-30°C ... +50°C	-40°C ... +60°C	-60°C ... +80°C
<b>First alarm switchpoint setting pressure abs. @ 20°C</b>					
≤ 650 kPa	[kPa max.]	± 10	± 12	± 14	± 15
> 650 kPa	[kPa max.]	± 10	± 14	± 16	± 18
<b>High pressure alarm <sup>1)</sup></b>	[kPa max.]	± 10	± 18	± 22	± 25

<sup>1)</sup> Only applicable if factory adjustment includes high-alarm switchpoint above filling pressure

### Process gas liquefaction alarm

**i** Arctic low temperatures can lead to liquefaction of process gas. Liquefaction causes a rapid pressure-drop that can temporarily trigger an alarm switchpoint. Gas density monitor 87x8 keeps the alarm status until the alarm trigger level is exceeded again while returning to normal condition.

Additional information		
<b>Documents</b>	Data sheet	<a href="http://www.trafag.com/H72513">www.trafag.com/H72513</a>
	Instructions	<a href="http://www.trafag.com/H73513">www.trafag.com/H73513</a>
	Flyer	<a href="http://www.trafag.com/H71104">www.trafag.com/H71104</a>

## Electrical connections

Standard wiring terminal

**87x8.20.XXXX.XX.XX.XX.XX**

Number of microswitches according to customer application

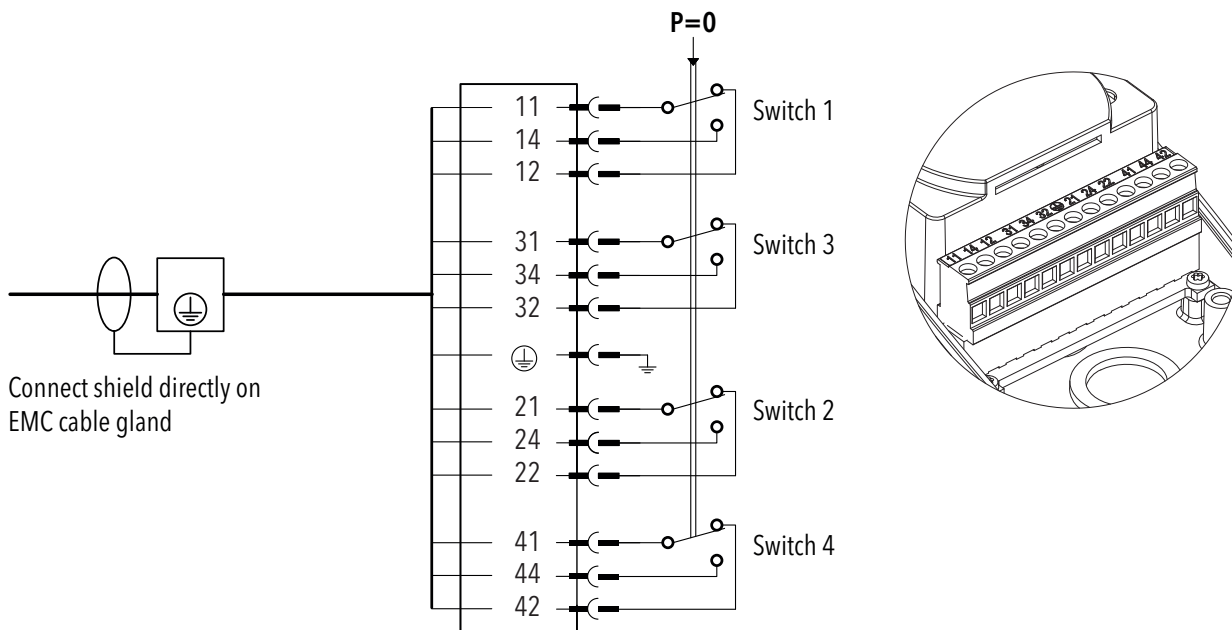

### Microswitch in non-pressurised condition (p=0)

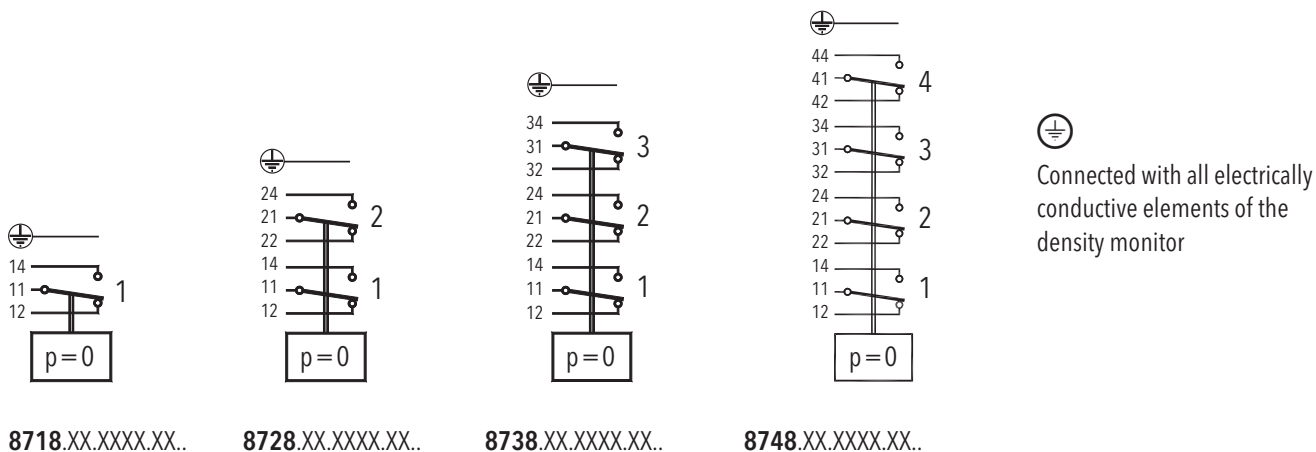

Instruction: [www.trafag.com/H73513](http://www.trafag.com/H73513)

## Electrical connections

### Connections for microswitch

<b>EMC-cable gland</b>	See ordering information
<b>Wire terminal</b>	Plugable, 0.2 ... 2.5 mm <sup>2</sup> , 13-pins
<b>Connector option</b>	ITT Cannon

EMC-cable gland

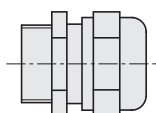

**87x8.XX.XXXX.XX.XX.XX.XX**  
Type code 07...17, see ordering information

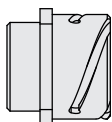
ITT Cannon connector <sup>1)</sup>

**87x8.XX.XXXX.XX.12.XX.XX**

Blank plug



**87x8.XX.XXXX.XX.XX.XX.XX**  
Type code 04...13, see ordering information

Microswitch connection either with EMC-cable gland,  
ITT Cannon connector or closed with blank plug

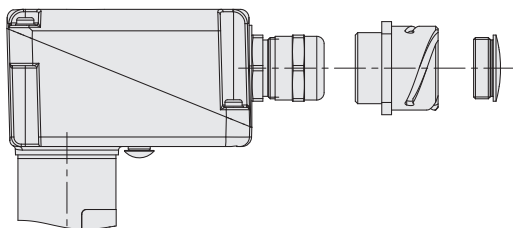

<sup>1)</sup> Monitor internal wiring provided. Please contact us for standard pin-out and more details.

Sheltering option with weather protection cover (46) and/or thermal insulation ring (06) for probe housing only

## Main dimensions of density monitor

Example model with axial process connection and cap nut

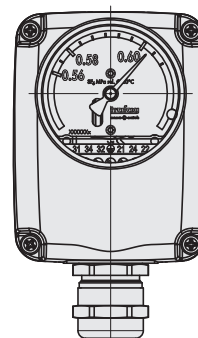
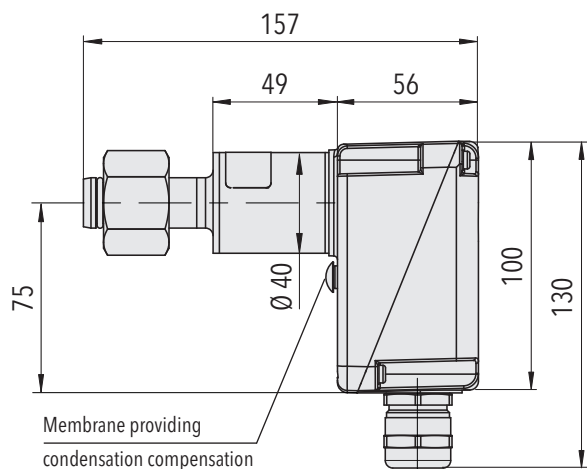

87x8.20.2XXX.XX.XX.XX.XX

Example model with radial process connection

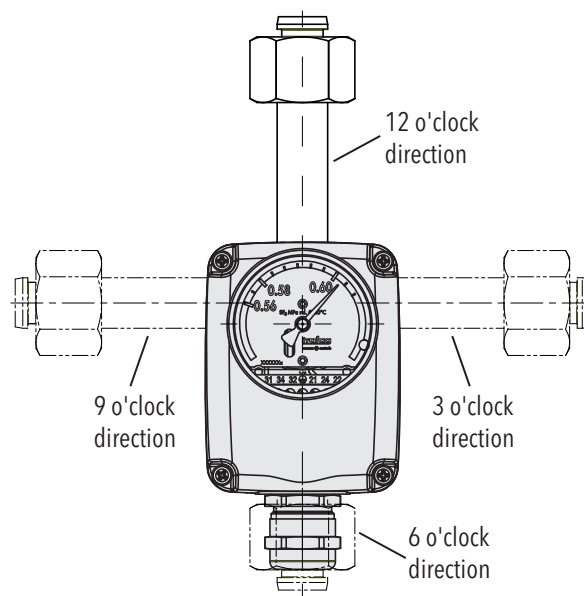
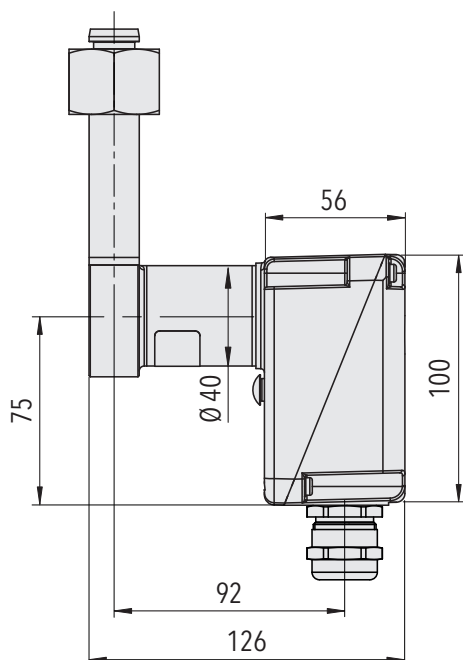

Radial process connection is configurable for 12/3/6/9 o'clock direction

87x8.20.1XXX.XX.XX.XX.XX



## Installation and sheltering options

Installation			
	Indoor application	Outdoor application	Outdoor application with rapidly changing or extreme weather conditions
<b>Installation orientation</b>	No limitations, any orientation possible	A, B, C <sup>1)</sup>	A, B, C <sup>1)</sup>
<b>Recommended option</b>	none	<ul style="list-style-type: none"> <li>■ Weather protection cover (46)</li> <li>■ Thermal insulation for probe housing (06)</li> </ul>	<ul style="list-style-type: none"> <li>■ Thermal foam cover (37)</li> <li>■ Compartment immersion type process connection (5XXX)</li> </ul>

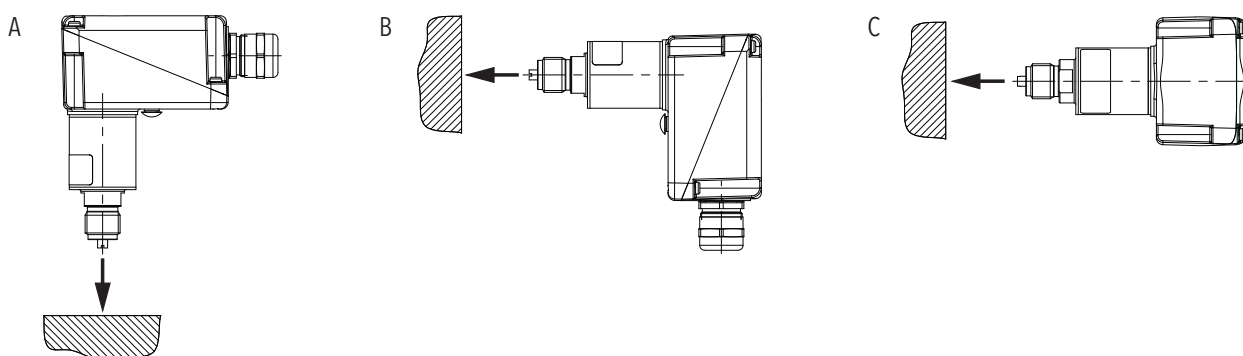

<sup>1)</sup> Or any orientation in between. A horizontal upside down installation shall be avoided

## Installation and sheltering options

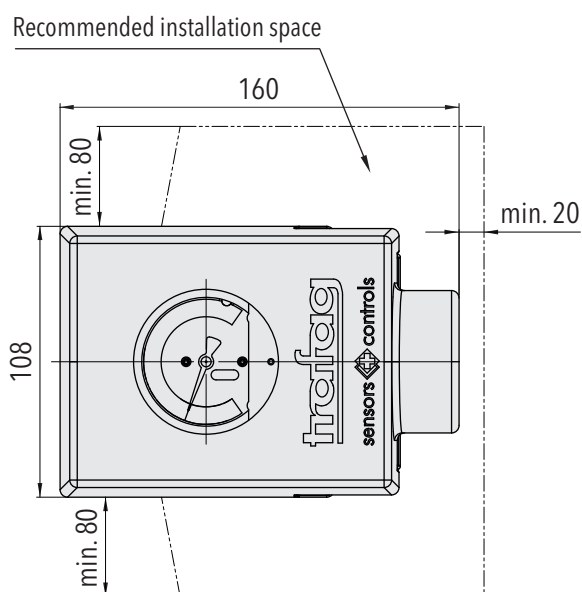
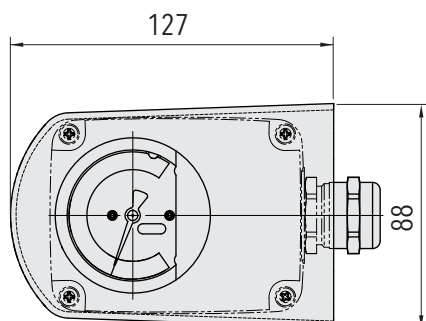
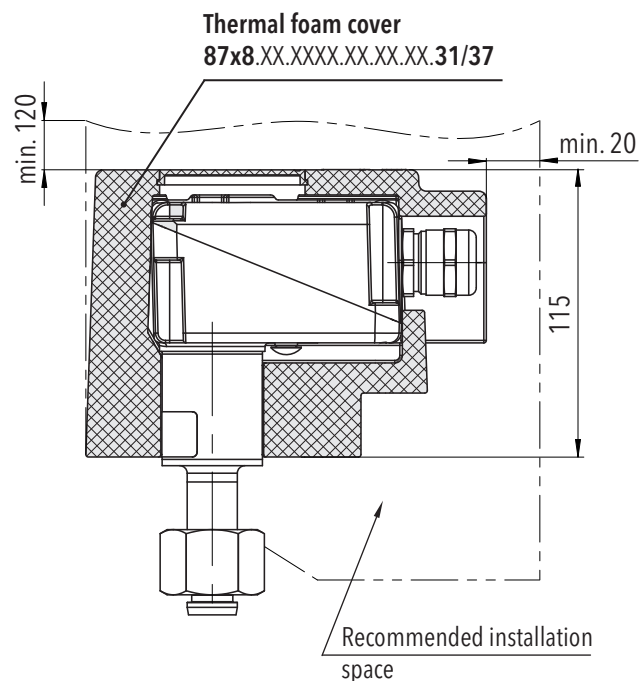
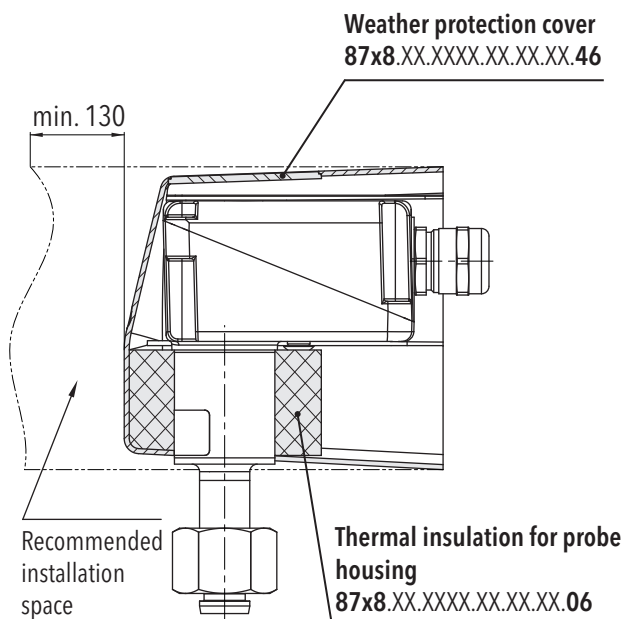

Weather protection cover (46) is aimed for long-term element protection. Insulation ring (06) for probe housing increases thermal inertia in moderate climates. Probe housing refers to the lower part of the monitor where the reference chamber is located.

Foam cover (31, 37) increases thermal inertia of the density monitor. It is recommended in locations with high solar radiation or diurnal temperature fluctuations (high altitude, arctic, desert).

## Installation and sheltering options

### Compartment immersion process connection

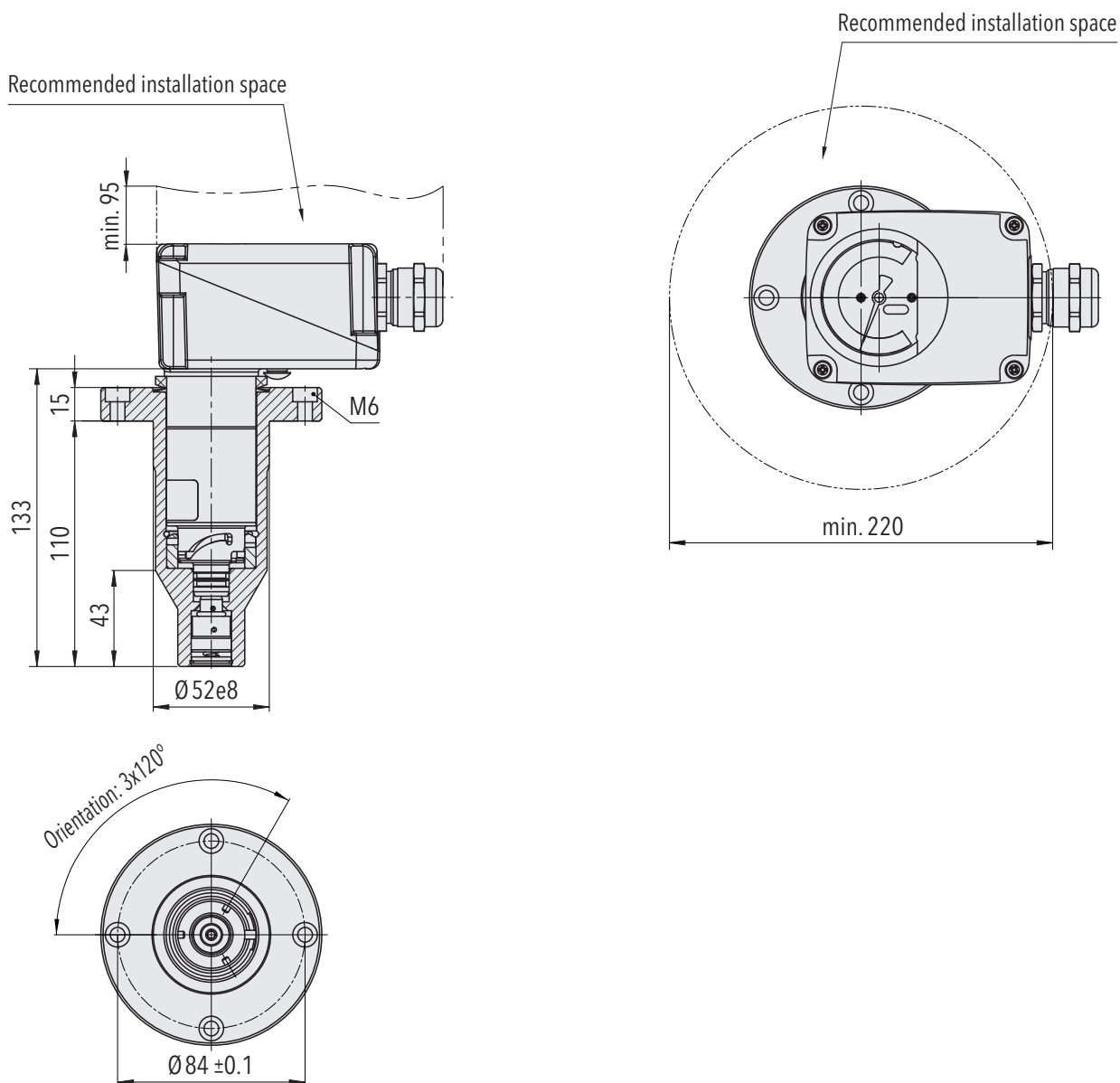

87x8.XX.5XXX.XX.XX.XX.XX

The in-compartment installation (5xxx) is aimed to match process gas and monitor probe temperature. Bayonet fitting allows installation while process is pressurized



Further details see datasheet: [www.trafag.com/H72502](http://www.trafag.com/H72502)

## Process connections

### Axial process connections

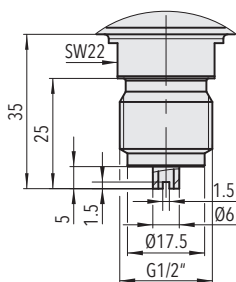

**87x8.XX.1000.XX.XX.XX.XX**  
Axial threaded connection G1/2"

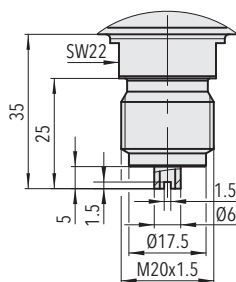

**87x8.XX.1120.XX.XX.XX.XX**  
Axial threaded connection M20x1.5

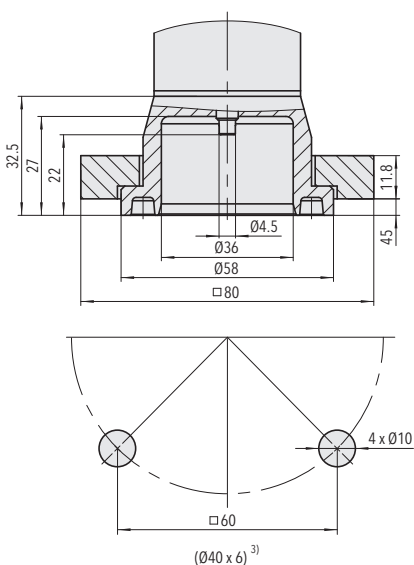

**87x8.XX.2000.XX.XX.XX.XX**  
Axial flanged connection

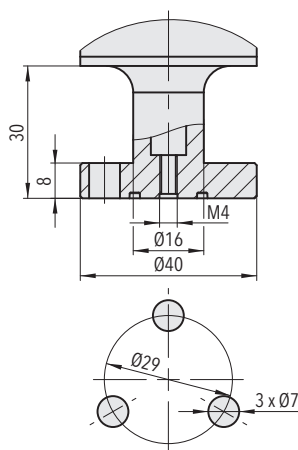

**87x8.XX.2200.XX.XX.XX.XX**  
Axial flanged connection

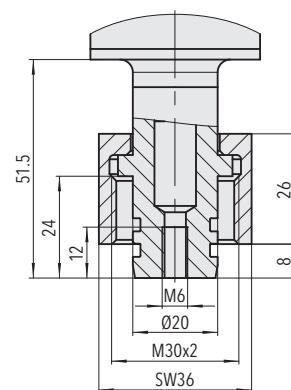

**87x8.XX.2300.XX.XX.XX.XX**  
Axial cap nut connection

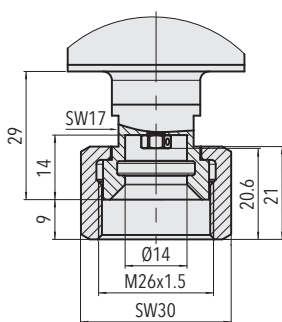

**87x8.XX.2550.XX.XX.XX.XX**  
Axial for DILO DN8 connection

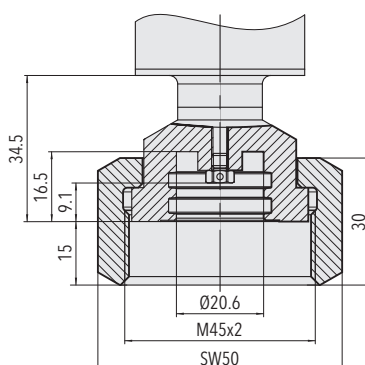

**87x8.XX.2570.XX.XX.XX.XX**  
Axial for DILO DN20 connection

## Process connections

### Radial process connections

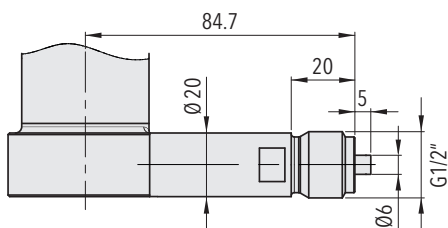

**87x8.XX.1030.XX.XX.XX.XX**

Radial threaded connection G1/2"

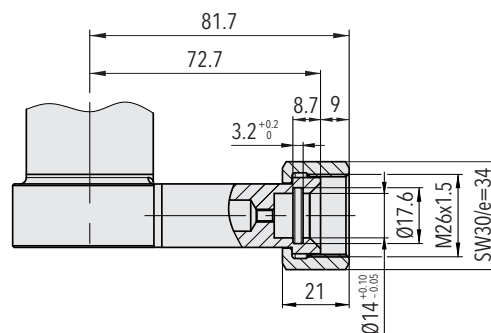

**87x8.XX.2XE2.XX.XX.XX.XX**

Radial for DILO DN8 connection

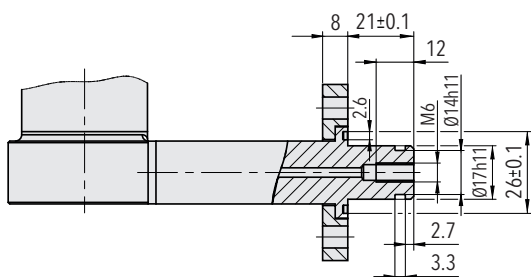

**87x8.XX.2XP2.XX.XX.XX.XX**

Radial for two-hole flange connection

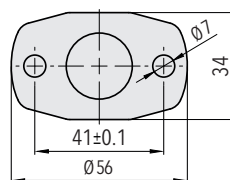

### Adapter

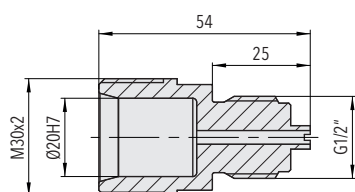

**87x8.XX.2300.XX.XX.XX.N1**

Adapter 2300 - G1/2" male for rotatable  
G1/2" pressure connection



Delivery includes assembly kit and O-Ring set where applicable

For full range of process connections and more details see data sheet: [www.trafag.com/H72502](http://www.trafag.com/H72502)

## Valve options

### Integrated test valve

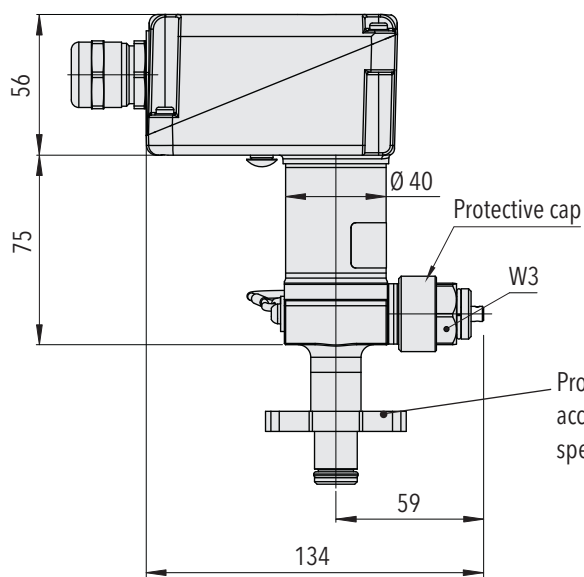

**87x8.XX.XXXX.XX.W0/W1/W2/W3.XX.XX**

Test valve allows in-situ monitor and sensor verification without dismounting from pressure compartment. Test equipment is connected via DILO DN8 port. Connection is configurable for direction W0/W1/W2/W3.

### Integrated re-filling valve

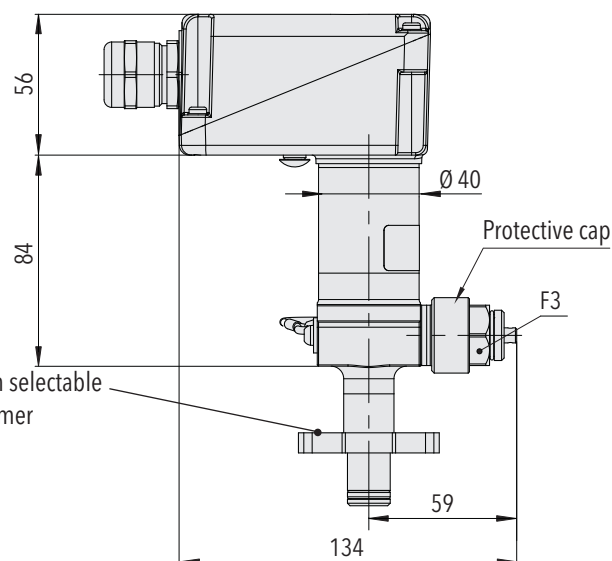

**87x8.XX.XXXX.XX.F0/F1/F2/F3.XX.XX**

Re-filling valve allows direct insulating gas replenishment of pressure compartment via DILO DN8 port on re-filling valve. Connection is configurable for direction F0/F1/F2/F3.

### Orientation service connection (top view) <sup>1)</sup>

please specify when ordering

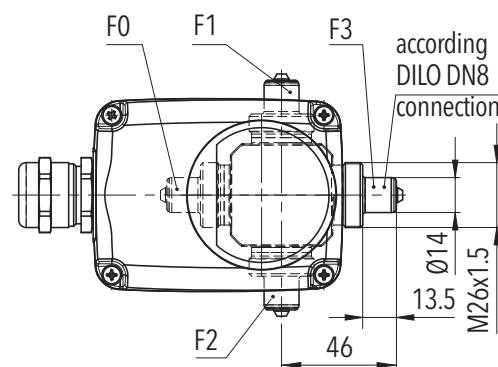
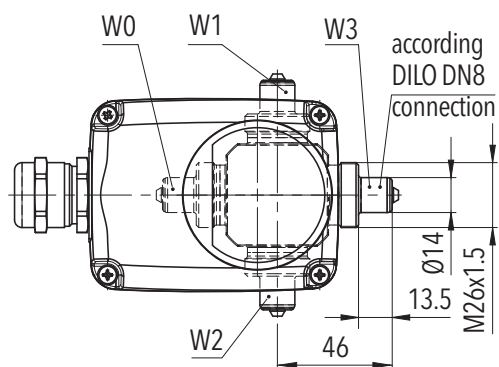

<sup>1)</sup> While using weather protection cover or thermal foam cover, the indicated installation spaces should be followed. See section installation and sheltering option

### Operating specification for test and re-filling valve:

Opening and closing shall be limited to temperature range of -25°C ... +50°C

Mechanical lifetime min. 250 actuation cycles



For more details see instruction: [www.trafag.com/H73521](http://www.trafag.com/H73521)

## Spare parts

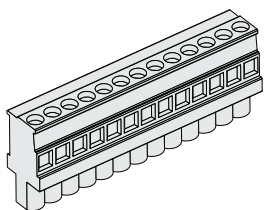

Standard microswitch wire terminal, 13-pins <sup>1)</sup>

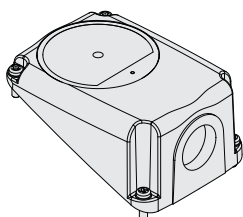

Housing cover with dial window <sup>2)</sup>

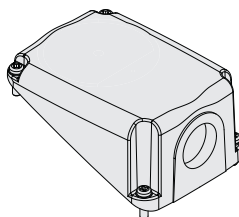

Housing cover without dial window <sup>2)</sup>

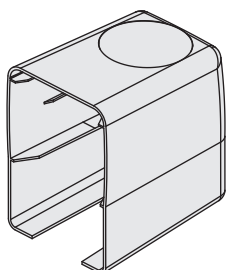

Weather protection cover  
(Trafag part no.: C16354)

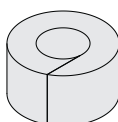

Thermal insulation for probe housing  
(Trafag part no.: D34570)

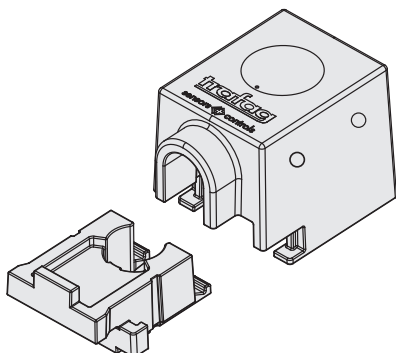

Thermal foam cover with drain hole  
(Trafag part no.: C16421)

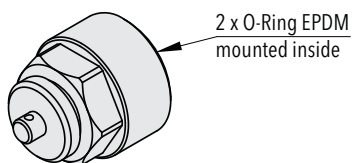

M26x1.5 protective cap for test and re-filling valve  
(Trafag part no.: C30645)

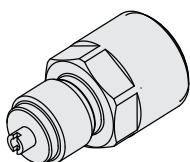

Pressure connection adapter 2300 - G1/2" male  
(Trafag part no.: C30931)

<sup>1)</sup> Please contact us for more details

<sup>2)</sup> Please identify if microswitch cable outlet is required. For options see ordering information